



NSB 155FT BLUE+

AGM Thin Plate Lead Carbon



The NSB BLUE+ Battery® delivers ultra fast recharge and exceptional PSoC cycling performance.

- Exceptional PSoC cyclic performance 2050 cycles @50% DoD
- Design life 12+ years at 20°C (68°F)
- EUROBAT design life definition: Very Long Life (12+ years)
- Ultra fast recharge
- Shelf life of up to 24 months
- High modulus Polyphenylene Oxide (PPO) plastic materials designed to withstand extended elevated operating temperatures and maintain high battery compression essential for reliable operation
- Flame retardant (UL 94 VO) and LOI of at least 28%
- Lead carbon added to negative electrodes increases power and reduces sulfation
- High potential fuel savings when used with hybrid genset applications
- Operating temperature range -40°C to +65°C (-40°F to 149°F)
- State-of-the-art automated manufacturing ensures consistency and reliability
- Advanced 3 stage terminal design to ensure leak-free operation - brass terminals provide maximum performance
- Non-halogenated thermally sealed plastic casing
- Approved as non-hazardous cargo for ground sea and air transport DOT 49CFR173.159(d), (i) and (ii)

NSB 155FT BLUE+

Nominal Technical Specifications

Dimensions

Height	280 mm	Width	125 mm
Length	560 mm	Weight	55 kg

Electrical

Terminal	Female M8 x 1.25
Terminal torque	8.0 Nm (71 in-lbs)
10 hr capacity to 1.80VPC @ 25°C (77°F)	150 Ah
8 hr capacity to 1.75VPC @ 25°C (77°F)	148 Ah
Float voltage @ 20/25°C (68/77°F)	2.28 / 2.27 VPC
Impedance (1Khz)	2.2 mΩ @ 25°C (77°F)
Conductance	2390 S
Short circuit current	5000 A
Maximum charge current (A)	No Limit
Operation temperature range	-40°C to +65°C
Nominal voltage	12 V

Technical Drawing

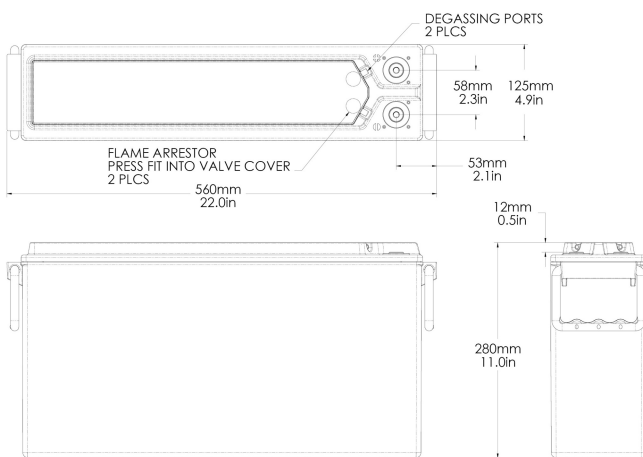

All NorthStar batteries are compliant with: Telcordia SR4228, IEC 60896; Bellcore GR-63-Core, Issue 1; British, German, and Russian telecom standards; UL approved and UN2800 certified. NorthStar is registered to ISO 9001 and ISO 14001.

NorthStar Americas PARTIAL
NorthStar Battery Company LLC
4000 Continental Way
Springfield, MO, 65803,
United States of America
info@northstarbattery.com
Tel: +1 417 575 8200
Fax: +1 417 575 8250

NorthStar Europe
SiteTel Sweden AB
Haukadalsgatan 8A
SE-164 40 Kista,
Stockholm, Sweden
europe@northstarbattery.com
Tel: +46 8 410 102 00
Fax: +46 8 638 06 00

NorthStar Middle East, Africa
NorthStar Battery DMCC
Office 702, Saba 1 Tower
Jumeirah Lake Towers, Dubai
United Arab Emirates
mea@northstarbattery.com
Tel: +971 4 423 8060
Fax: +971 4 423 8061

NorthStar Asia-Pacific
NS Asia Pacific Sdn. Bhd.
B2-3A-13A, Solaris Dutamas
No. 1, Jalan Dutamas 1, 50480
Kuala Lumpur, Malaysia
asia@northstarsitetel.com
Tel: +60 3 6419 0711